

Guidelines on  
**Spectral Fatigue Analysis  
of Ship Structures**

**2020**



**IRCLASS**  
Indian Register of Shipping

# Guidelines on Spectral Fatigue Analysis of Ship Structures 2020

## Contents

## Sections

- 1. Introduction**
  - 1.1 General
  - 1.2 Methodology and Assumptions
- 2. Procedure for Spectral Fatigue Analysis**
  - 2.1 General
  - 2.2 Loading Conditions
  - 2.3 Hydrodynamic Analysis
  - 2.4 Structural Analysis
  - 2.5 Spectral Analysis
  - 2.6 Fatigue Damage Assessment
- 3. Environmental Conditions**
  - 3.1 Wave Scatter Diagram
  - 3.2 Wave Spectrum
  - 3.3 Short Crested Sea
  - 3.4 Wave Headings
- 4. Hydrodynamic Analysis**
  - 4.1 General
  - 4.2 Scope of the Hydrodynamic Analysis
  - 4.3 Hydrodynamic Model
  - 4.4 Still Water Calibrations
  - 4.5 Analysis Methods
  - 4.6 Analysis Results

## **5. Structural Analysis**

- 5.1 General
- 5.2 Coordinate System
- 5.3 Finite Element Modelling
- 5.4 Weight Representation
- 5.5 Quasi-Static and Inertial Loads
- 5.6 Pressure Mapping
- 5.7 Boundary Conditions
- 5.8 Structural Modelling
- 5.9 Structural Analysis

## **6. Spectral Analysis**

- 6.1 General
- 6.2 Response Spectrum
- 6.3 Spectral Moments
- 6.4 Rain-flow Correction

## **7. Fatigue Damage Assessment**

- 7.1 General
- 7.2 Fatigue Stress Range
- 7.3 S-N Curve
- 7.4 Fatigue Strength
- 7.5 Close Form Damage Expressions
- 7.6 Combined Fatigue Damage
- 7.7 Acceptance Criteria

### **Appendix – 1 Scatter Diagram**

### **Appendix – 2 Design S-N Curves**

### **Appendix – 3 Hot-spot Stress Extraction**

**Abbreviations:**

<i>AP</i>	<i>: Aft perpendicular</i>
<i>BL</i>	<i>: Base line</i>
<i>CG</i>	<i>: Centre of gravity</i>
<i>CL</i>	<i>: Centre line</i>
<i>EDW</i>	<i>: Equivalent design wave</i>
<i>FE</i>	<i>: Finite element</i>
<i>FEM</i>	<i>: Finite Element Method</i>
<i>FP</i>	<i>: Forward perpendicular</i>
<i>IACS</i>	<i>: International Association of Classification Societies</i>
<i>IRS</i>	<i>: Indian Register of Shipping</i>
<i>LCB</i>	<i>: Longitudinal centre of buoyancy</i>
<i>LCF</i>	<i>: Longitudinal centre of flotation</i>
<i>LCG</i>	<i>: Longitudinal centre of gravity</i>
<i>P-M spectrum</i>	<i>: Pierson–Moskowitz spectrum</i>
<i>RAO</i>	<i>: Response amplitude operator</i>
<i>TCG</i>	<i>: Transverse centre of gravity</i>
<i>VCG</i>	<i>: Vertical centre of gravity</i>
<i>RAO</i>	<i>: Response Amplitude Operator</i>
<i>SFA</i>	<i>: Spectral Fatigue Analysis</i>

## Section 1

### Introduction

#### 1.1 General

1.1.1 The present guidelines provide a detailed description of the methodology to perform **Spectral Fatigue Analysis (SFA)**. In general, spectral based fatigue analysis may be performed by carrying out computation of wave induced loads in frequency domain for the loading conditions for specific vessel type, application of loads to the structural model to generate the stress Response Amplitude Operators (RAOs) and then obtaining the response spectrum at each location of interest by considering the environment.

1.1.2 Spectral based fatigue analysis is to be performed on ship structures, whenever required in addition to the simplified fatigue analysis as specified by owner or stakeholders.

1.1.3 A detailed report of spectral based fatigue analysis needs to be submitted for IRS approval, including the details of software/program used and along with the list of critical structural locations.

1.1.4 Additional information regarding the software/program used for the fatigue assessment may be requested if the submitted software/program details are found insufficient.

1.1.5 On satisfactory evaluation of the Report, an optional class notation **SFA ( )** may be assigned to the vessel. The design fatigue life (in years), which has been assessed by analysis would be indicated in the parentheses.

1.1.6 The guidelines include the welded joints/attachments or stress concentration locations which can be a potential source of fatigue crack in ships.

#### 1.2 Methodology and Assumptions

1.2.1 The spectral fatigue analysis is based on the direct computation of wave loads for selected loading conditions and wave environment. The wave loads are directly applied on the FE model of ship to determine the stress transfer function. The wave loads include the external wave pressure, internal pressure and inertial forces due to rigid body motion.

1.2.2 The short term stress range variation for a given sea state is assumed to be random, narrow banded and stationary process. Therefore, Rayleigh distribution can be used to represent the short term stress range distribution.

1.2.3 Fatigue capacity is represented by the S-N curve for the structural location under the consideration. Spectral fatigue damage for the structural location typically can be represented by the ratio of the stress range distribution to its fatigue capacity. The essential steps in performing the SFA for the structural location are as follows:

- Determination of stress range distribution
- Calculation of fatigue capacity (S-N data)
- Calculation of fatigue life

Section 2 provides the overall procedure to carry out Spectral fatigue analysis

1.2.4 Various valid approaches can be followed to carry out the spectral based fatigue analysis. However it is necessary to consider the underlying assumptions and key elements that form the basis of any such valid technique to produce acceptable results.

1.2.5 The main assumptions in performing spectral based fatigue analysis are:

- Wave induced load effects are considered as the main source for cyclic stresses.
- The computation of loads and structural response are performed based on the linear assumption.
- The effect of non-linear roll motion and intermittent loads particularly in the side shell region, is to be accounted using a correction factor.
- The procedures do not take into account the effect of low cycle fatigue due to loading and unloading cycles.

## Section 2

### Procedure for Spectral Fatigue Analysis

#### 2.1 General

2.1.1 A flow chart outlining the basic steps involved in *SFA* for ships is given in Fig. 2.1.1.

2.1.2 During its life, the vessel may be subject to various loading conditions. Suitable and most probable loading conditions specific to ship type are to be reviewed and selected as per Section 2.2.

2.1.3 Hydrodynamic and structural analysis need to be performed for each selected loading condition. For determining the damage occurred in each loading condition, fraction of ship life spent in each loading condition (as estimated) is to be reviewed and used.

#### 2.2 Loading Conditions

2.2.1 Standard representative loading conditions are to be selected from ship's loading manual and are to be as per the IRS rules. At least two loading conditions are to be analysed – one representative of the most probable deepest draft and one representative of the most probable shallowest draft.

2.2.2 For other and special ship types for which standard loading conditions are generally not defined, the selection of loading conditions are to be performed in consultation with *IRS*.

#### 2.3 Hydrodynamic Analysis

2.3.1 Hydrodynamic analysis is to be performed to determine the vessel's response to unit wave amplitude, referred to as Response Amplitude Operators (*RAO*). Hydrodynamic analysis is to be performed for the standard loading conditions as defined in 2.2.

2.3.2 State of the art 3D panel methods are recommended for the hydrodynamic analysis.

2.3.3 An appropriate facet model up to mean waterline needs to be prepared by incorporating the weight distribution, consistent with the FE mass model.

2.3.4 Detailed procedures to carry out hydrodynamic analysis are given in Section 4.

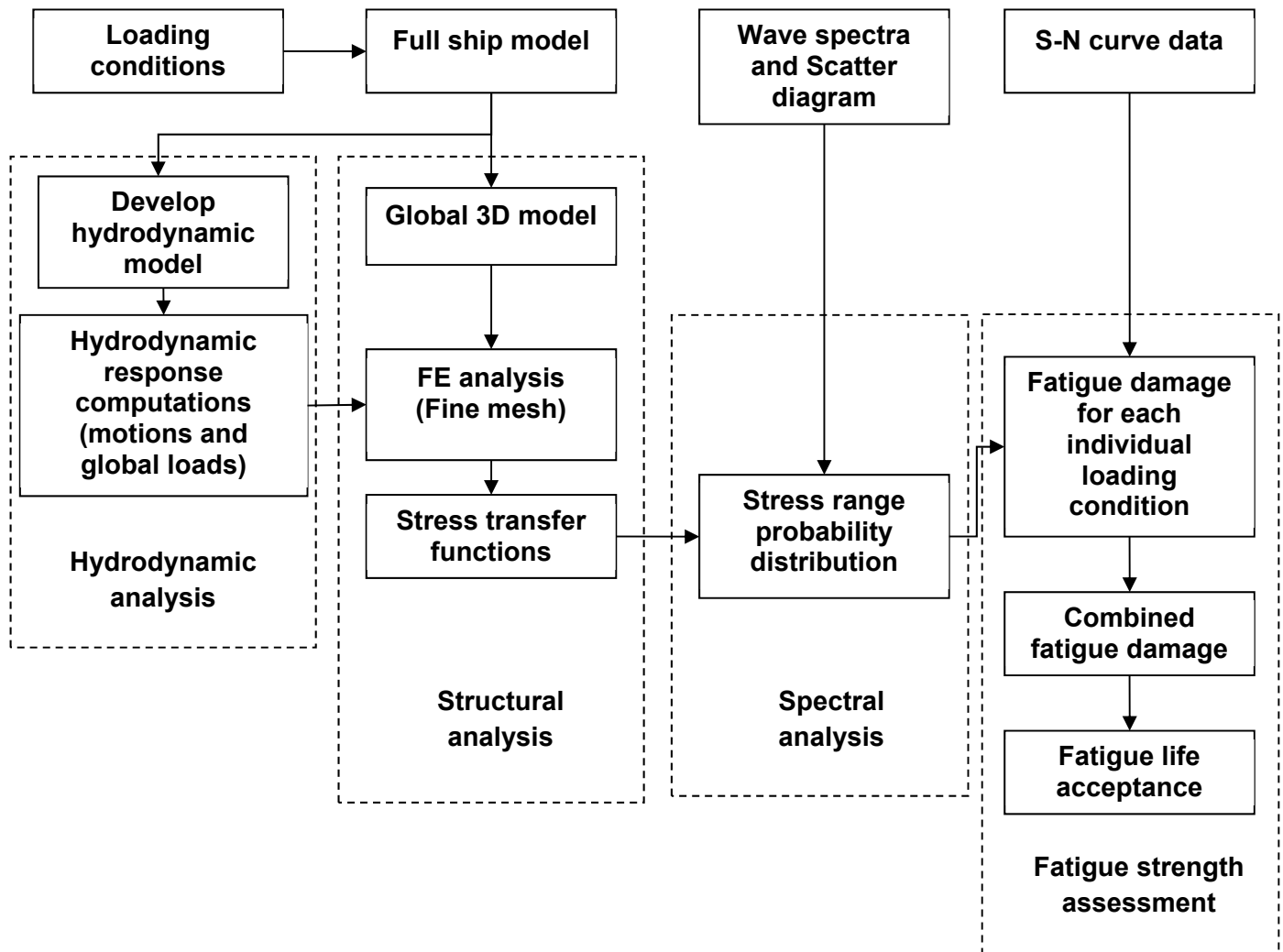

Fig. 2.1.1: Procedure for Spectral-based Fatigue Assessment

## 2.4 Structural Analysis

2.4.1 Structural analysis is to be performed to obtain the stress transfer function. This process involves the following tasks:

- Creation of global 3D structural Model
- Application of direct hydrodynamic loads
- Calculation of stress transfer function

The detailed procedure for structural analysis is given in Section 5.

## 2.5 Spectral Analysis

2.5.1 Spectral analysis needs to be performed post stress transfer function evaluation using a wave spectrum, as explained in Section 6.



2.5.2 A suitable scatter diagram is to be referred, based on the area of operation or trade route or service type.

2.5.3 The stress response function and spectral moments are to be calculated based on the wave spectrum and wave scatter diagram. Stress spectral moments are used to determine the zero up-crossing frequencies, bandwidth parameters and stress range probability density functions.

## **2.6 Fatigue Damage Assessment**

2.6.1 The fatigue capacity of structural elements or joints is represented by S-N curve (refer to '**Appendix - 2**'). The choice of S-N curve relies on the type of stress considered for the analysis and the configuration of the structural joint.

2.6.2 Fatigue damage contribution needs to be evaluated for each loading condition as specified in 2.2. The short term fatigue damage can be calculated for all the sea states for the given time span using the short term stress distribution and the S-N data. Long term fatigue damage can be predicted using Miner's Rule for linear cumulative summation of short term fatigue damages.

2.6.3 Detailed procedure to perform fatigue damage assessment is described in Section 7.

## Section 3

### Environmental Conditions

#### 3.1 Wave Scatter Diagram

3.1.1 Scatter diagrams provide the long term description of the sea states encountered by the ship and typically represent the joint probability/ occurrence of significant wave height,  $H_s$  and representative wave period,  $T_z$  combination during the discrete time period of measurement.

3.1.2 In general, the scatter diagram of the North Atlantic Ocean, (refer Table A.1.1 in **Appendix – 1**) is to be used for vessels intended for worldwide unrestricted service. This scatter diagram is to be applied to the vessels frequently sailing on North Atlantic routes for *SFA*.

3.1.3 In the case of vessels not plying frequently to North Atlantic Ocean, relatively less severe environmental conditions may be used. When the voyage profile of vessel is known and fixed, wave climatic conditions may be estimated as the weighted average of the available wave statistics from Marsden zones.

#### 3.2 Wave Spectrum

3.2.1 Standard unidirectional energy wave spectra usually represented by the two parameters i.e. significant wave height ( $H_s$ ) and ( $T_z$ ).  $H_s$  and  $T_z$  are to be used to describe a wave frequency spectrum in standard form.

3.2.2 Pierson-Moskowitz (*P-M*) spectrum is used for the description of each short term sea state and generally considered for the *SFA* of ships. The two parameter P-M spectrum defined by *IACS* (*IACS* Rec. 34) for North Atlantic is given by the following expression as:

$$S_{\xi}(\omega) = \frac{H_s^2}{4\pi} \left( \frac{2\pi}{T_z} \right)^4 \omega^{-5} \exp \left( -\frac{1}{\pi} \left( \frac{2\pi}{T_z} \right)^4 \omega^{-4} \right)$$

Where,

$H_s$	= Significant wave height [m]
$T_z$	= Average zero crossing period [s]
$\omega$	= Angular Wave frequency [rad/sec]

3.3.3 The spectrum is to be generated for sufficient number of wave frequencies and contain the frequencies corresponding to maximum wave energy.

#### 3.3 Short Crested Sea

3.3.1 Short crested sea way is the representation of three-dimensional irregular seaway by distribution of wave energy over frequencies and directions at a point.

3.3.2 A cosine-square direction spreading of wave energy is often used and applied to the unidirectional wave energy spectrum. Fig. 3.4.2 shows the wave spectra with directional spreading for the following sea dominant direction. Formula for the directional spreading is given by:

$$G(\omega, \mu) = \left\{ \frac{2}{\pi} \cdot \cos^2(\mu - \bar{\mu}) \right\} \cdot S_{\xi}(\omega)$$

$$-\frac{\pi}{2} \leq (\mu - \bar{\mu}) \leq +\frac{\pi}{2}$$

Where,

- $\mu$  = Dominant wave heading
- $\bar{\mu}$  = Component wave heading
- $S_{\xi}(\omega)$  = Unidirectional wave energy spectrum

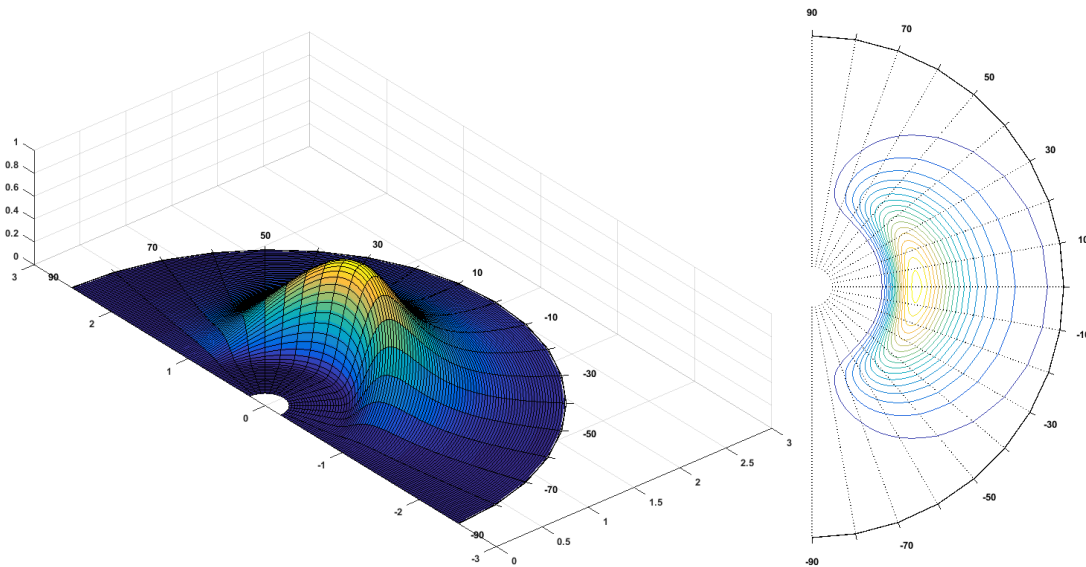

Figure 3.4.1 : Wave spectra with directional spreading

### 3.4 Wave Headings

3.4.1 Wave heading angles are to be taken in the range of 0 degree to 360 degrees covering the full directional spectrum with a maximum spacing of 30 degree applied between headings.

3.4.2 An equal probability of occurrence of ship heading with respect to direction of wave is to be taken.

## Section 4

### Hydrodynamic Analysis

#### 4.1 General

4.1.1 This Section provides details of the procedures to compute wave induced ship responses for the unit wave amplitude, termed Response Amplitude Operator (*RAO*) using frequency domain seakeeping program.

4.1.2 Motions and hydrodynamic pressure *RAOs* are to be computed for the ship in each loading condition.

4.1.3 A consistent ship co-ordinate system is to be used for hydrodynamic and FE analysis.

4.1.4 Full ship geometry is to be used to create different analysis cases based on the selected standard loading conditions as specified in 2.2. Hydrodynamic models are to be created for each corresponding loading condition. Sea-keeping programs based on 3D panel methods are recommended for the hydrodynamic analysis.

#### 4.2 Scope of the Hydrodynamic Analysis

4.2.1 *RAOs* for ship motion and wave pressure are to be computed for each loading condition of vessel expected to be encountered during its lifetime. The ship motion and wave pressure *RAOs* are to be calculated for specific set of wave heading, frequency, vessel loading condition and ship's speed.

4.2.2 Hydrodynamic analysis needs to be carried out for 75% of the vessel design speed. A frequency range of 0.1 to 2.0 rad/sec for minimum 25 frequencies is considered adequate. However, intermediate frequencies needs to be adjusted to capture the resonance frequency.

4.2.3 Wave headings are required to be considered in accordance with Section 3.4

#### 4.3 Hydrodynamic Model

4.3.1 Hydrodynamic model corresponding to each loading condition needs to be prepared by maintaining the mass properties and hydrostatic parameters in balance and as mentioned in the loading manual.

4.3.2 Facet model is to be prepared from the vessel geometry as preliminary requirement for the application of 3D panel method based boundary element methods.

4.3.3 Typical number of panels over the body surface will depend on the ship geometry, and may vary between 800 ~ 1500 for half ship of ordinary ship shapes. For complex hull shapes, number of panels may increase. The panel size must be smaller than 1/8th of the wave length corresponding to frequency for which the computation is being performed.

4.3.4 A proper weight distribution is required to form mass matrix for hydrodynamic analysis. Weight distribution must be consistent with the mass model being used for *FE* model.

4.3.5 Roll damping based on experiments is to be used. In case Roll motion damping is not known, linear roll damping coefficient is to be taken as 5 ~ 8% depend on the type of ship.

## 4.4 Still Water Calibration

4.4.1 Initially, model needs to be balanced in free floating condition in still water with corresponding mass distribution. This static balance condition is required to be checked before commencing the hydrodynamic analysis for all the selected loading conditions.

4.4.2 Hydrostatic parameter must be computed for the static balance condition and should not deviate much from the original loading conditions as defined in the loading manual. These parameters must be within  $\pm 3.0\%$ .

4.4.3 Still water bending moments (SWBM) and shear force along the ship length need to be determined and plotted. SWBM must be within 5% of the loading manual with tending to zero towards the forward and aft end of the ship. Fig. 4.4.3 shows a typical sample plot for alternate loading condition for a Bulk Carrier.

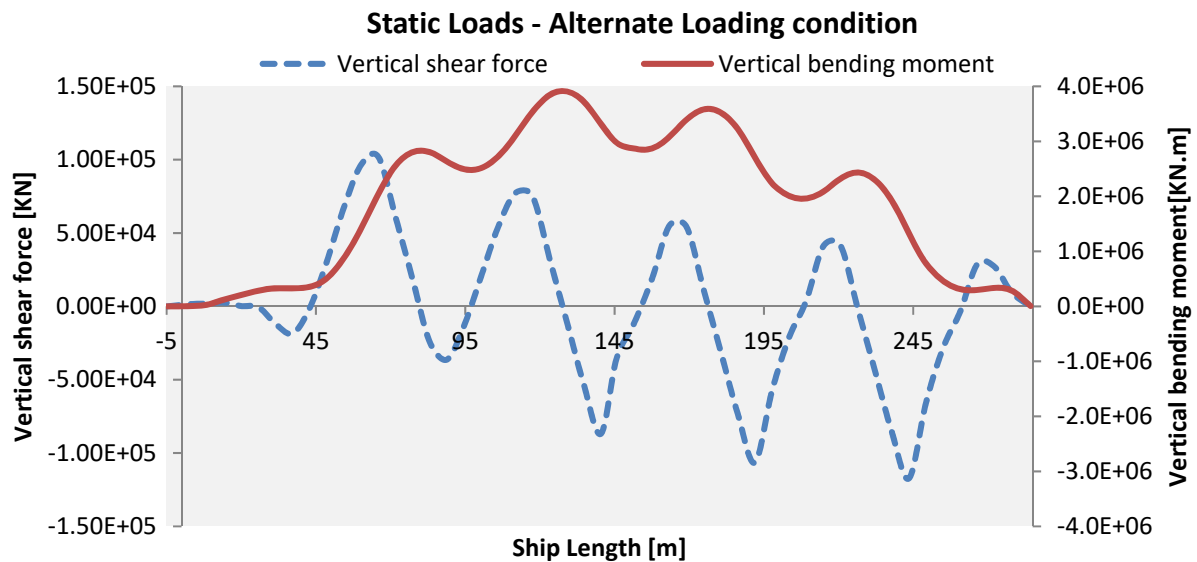

Figure 4.4.2 : Still water bending moment and shear force plot

## 4.5 Analysis Methods

4.5.1 3D potential theory based on radiation and diffraction program is to be used for the computation of wave induced motions and loads. Rigid body motions and wave pressure are to be solved by setting the body free in all six degree of freedom.

4.5.2 The analysis software is to be industry standard or validated against other proven tools or experiments.

## 4.6 Analysis Results

4.6.1 Hydrodynamic analysis results are represented as *RAOs* of motions and loads in frequency domain for various combinations of wave headings, vessel speed and loading conditions. These results are to be exported and applied on global *FE* model as detailed in Section 5.

## Section 5

### Structural Analysis

#### 5.1 General

5.1.1 A structural analysis is to be performed to evaluate the stress transfer functions required for spectral fatigue analysis. The stress transfer functions are used in the spectral analysis to compute the response spectrum, as discussed in Section 6. Computed wave induced loads (RAOs) are to be transferred to the FE model and the structural response in form of stress transfer function is to be obtained.

5.1.2 This Section details the procedure to compute the structural response using finite element analysis,

5.1.3 It is assumed that the structural model is created by following typical FE modelling procedure. Structural geometry, material properties and stiffness properties are to be simulated appropriately in the model.

5.1.4 Present guidelines considered only the sea-keeping loads e.g. motion and wave induced loads on ship's hull. Sloshing loads are not taken into account. If deemed necessary by IRS, then designer would be requested to submit such calculations.

#### 5.2 Coordinate System

5.2.1 The global coordinate system of ship geometry, motion, accelerations and loads are to be defined with respect to right handed coordinate system as shown in Figure 5.2.1.

5.2.2 The coordinate systems of structural analysis and sea-keeping analysis are recommended to be kept similar to avoid discrepancies in load transfer. In case of differences, appropriate measures are to be taken by the user.

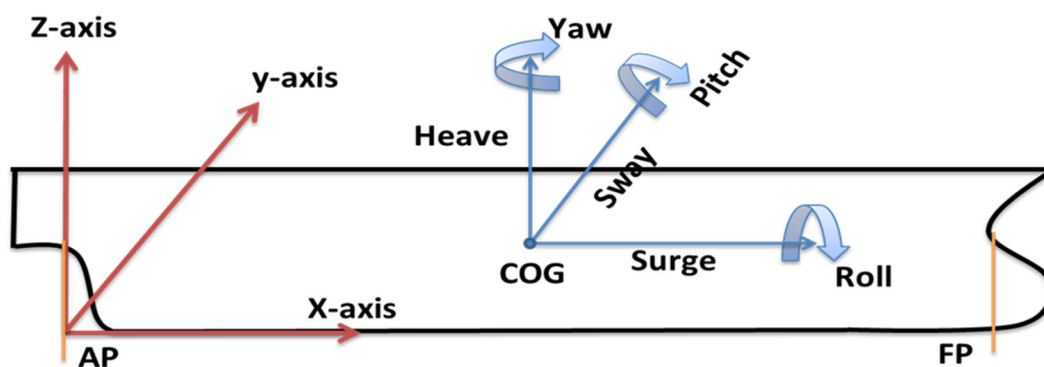

Figure 5.2.1: Reference coordinate system

## 5.3 Finite Element Modelling

### 5.3.1 Global Model

5.3.1.1 A model representing the entire hull structure is to be created for FE analysis. All primary and most of the secondary structural members are to be modeled in order to simulate the stiffness of hull girder appropriately. All types of weights are to be incorporated in FE model as indicated in 5.4.

### 5.3.2 Local Model

5.3.2.1 Localised fine mesh structural model is to be prepared to obtain the hot-spot stress at selected location for spectral fatigue analysis. The variation of mesh from coarse to fine should be gradual to capture the stress transfer function with higher accuracy. The detailed procedure of stress extraction can be referred in Appendix 3.

## 5.4 Weight Representation

### 5.4.1 Lightship Weight

5.4.1.1 The lightship weights are to be simulated by providing the density of material or using nodal mass elements. Minor differences in the lightship weight of FE model from actual can be adjusted by providing lumped mass. The procedure is to be performed such a manner that CG of structural model in all three direction remains identical to that given in loading manual/ stability booklet.

### 5.4.2 Ballast and Bunker

5.4.2.1 Ballast and Bunker weights can be represented as tank pressures. The appropriate tank boundaries are to be selected for pressure application. The appropriate pressures acting on internal surfaces of liquid tanks are to be calculated and are to be applied to selected entities in the FE model. Figure 5.4.2 shows an illustrative distribution of ballast pressure in representative tanks.

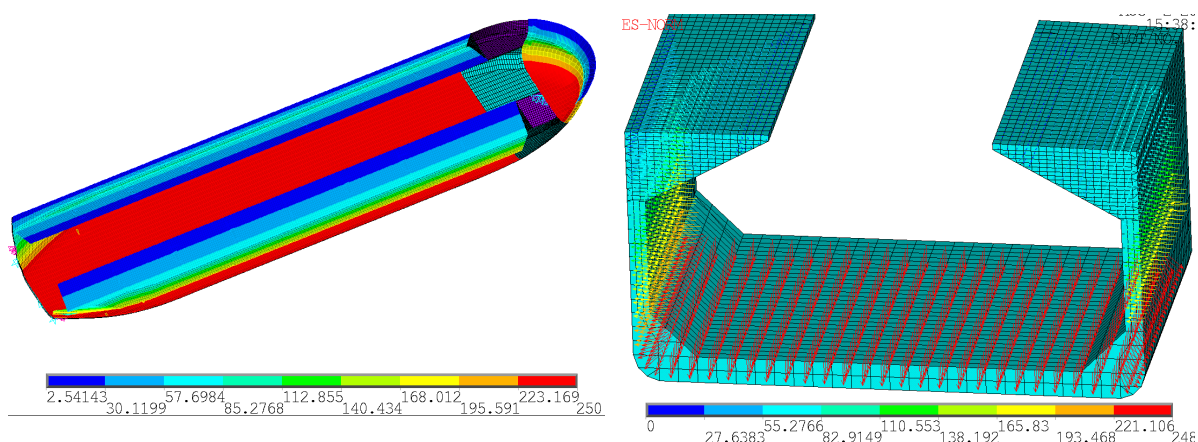

Figure 5.4.2: Illustrative distribution of ballast pressure in normal ballast conditions of a bulk carrier

### 5.4.3 Cargo Pressure

#### 5.4.3.1 General

5.4.3.1.1 The cargo weights are modeled for considering the loading condition as detailed in 2.2.

#### 5.4.3.2 Liquid

5.4.3.2.1 Liquid pressure can be simulated as tank pressure as discussed in 5.4.4.2.

#### 5.4.3.3 Grain/Ore

5.4.3.3.1 The bulk cargo masses are to be simulated using point/lumped mass element at the CG of respective cargo holds. The rigid body elements or equivalent suitable elements are to be used to connect the mass element to relevant hold surfaces. Connection of rigid body elements is to be made with cargo hold's bottom, bulkhead stool plating and hopper sloping tank's plating. A representative case using coupling elements (surface based constraint) is shown in Figure 5.4.3.3.1 User must verify the CG of each tank with the loading manual after distribution of cargo loads.

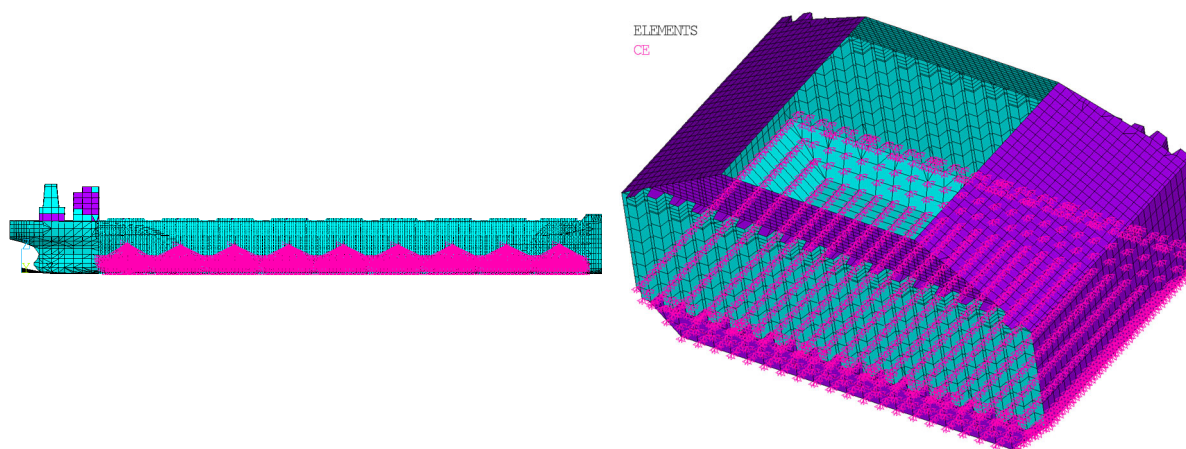

**Figure 5.4.3.3.1: Illustrative distribution of cargo loads in homogeneous condition**

#### 5.4.3.4 Containers

5.4.3.4.1 Containers can be distributed as point/lumped masses with no moment of inertia (at the centre of gravities of the containers) connected using rigid body elements. The rigid body element links the mass element to the corresponding nodes on the hold's bottom or on hatch-cover. One must ensure the connectivity of elements and also verify the CG of system after weight distribution. Container distribution on deck and in hold using coupling elements is shown in Figure 5.4.3.4.1 for illustration purpose.



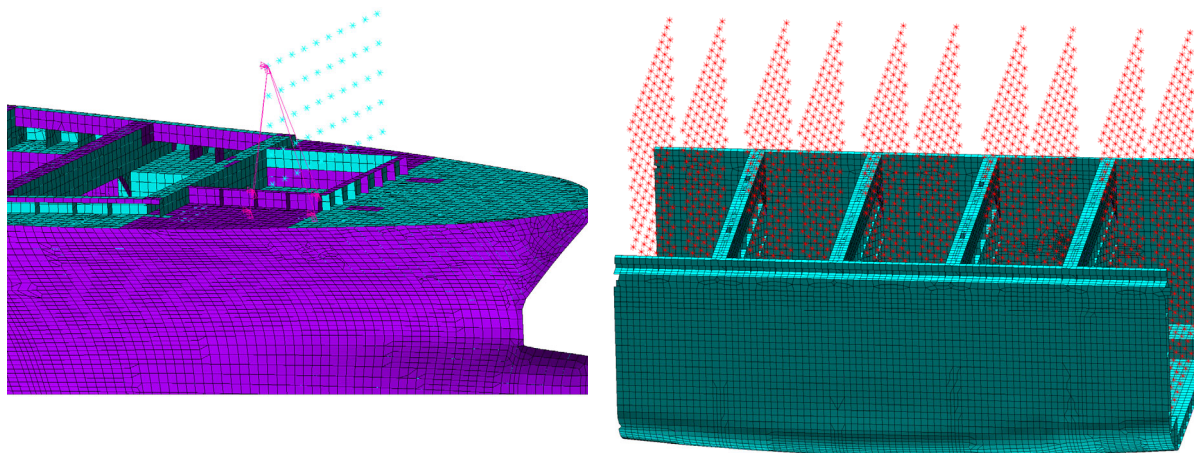

Figure 5.4.3.4.1: Illustrative distribution of containers on deck and in hold respectively

## 5.5 Quasi-static and Inertial Loads

### 5.5.1 General

5.5.1.1 Each type of loads discussed above (5.4.1 to 5.4.3) consist of static and dynamic load components. The gravity is responsible for static loads while dynamic load is induced due to ship motions. The dynamic loads can be decomposed into quasi-static and inertial loads. The quasi-static components are the part of gravity loads induced due to ship's roll and pitch inclination. The directions of resultant gravity loads in ship's fixed coordinate system are to be evaluated as shown in Figure 5.5.1.1 with the variation of roll and pitch motion respectively. The inertial loads in FE model are to be simulated by using the Equation (1). All the relevant inputs (ship motions and accelerations) for Equation (1) are to be obtained from sea-keeping analysis.

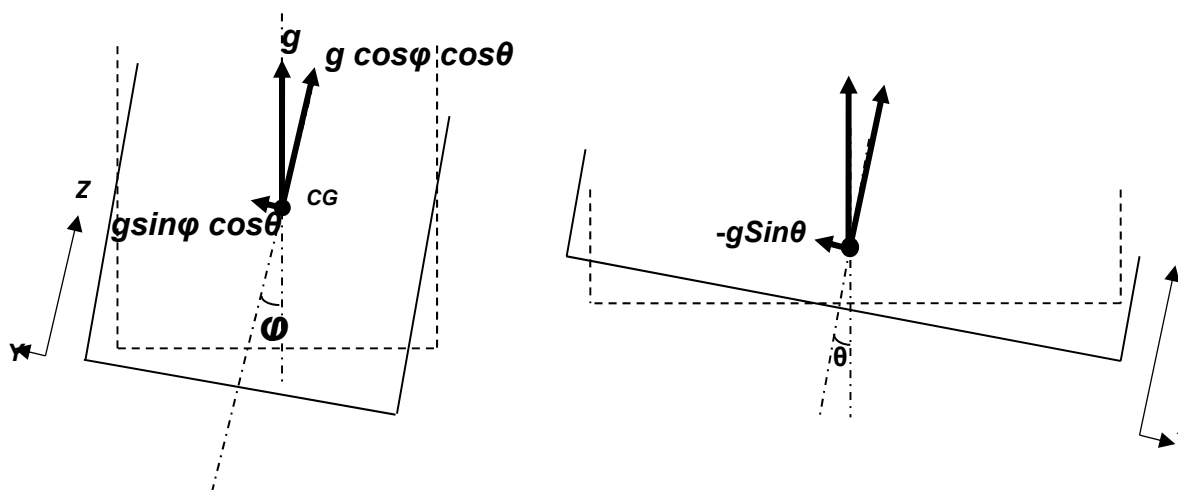

Figure 5.5.1.1: Inertial load computation

$$\vec{A}_e = \vec{A} + \vec{\Theta} \times \vec{R} \quad (1)$$

where:

$\vec{A}$  : Acceleration vector at ship's CG can be estimated as follows

in respective directions using Equation. (2), (3), (4) as follows

$$A_x = -g \sin \theta + a_x \quad (2)$$

$$A_y = g \sin \phi \cos \theta + a_y \quad (3)$$

$$A_z = g \cos \phi \cos \theta + a_z \quad (4)$$

$\vec{\theta}$	: Roll, pitch and yaw acceleration vector
$\vec{R}$	: Distance vector from ship's CG to the calculation point
$a_x, a_y, a_z$	: Accelerations (surge, sway, heave) due to ship motions
$\theta$ and $\phi$	: Pitch and roll angle respectively given by sea keeping program

$-g \sin \theta, g \sin \phi \cos \theta, g \cos \phi \cos \theta$  are the quasi-static components in x, y and z direction respectively with reference to ship's fixed coordination system due to combined motions of roll and pitch.

## 5.5.2 Liquid

5.5.2.1 Static and dynamic pressures on the completely and partially filled tanks are to be taken into account. Appropriate boundaries of tanks are to be considered as discussed in 5.4.2.

5.5.2.2 The static and dynamic liquid tank pressure can be estimated using Equation (5). However, in case of application of only dynamic loads (when potential theory based frequency domain code used), the static pressure components needs to be excluded appropriately:

$$P = P_0 + \rho_l h_i g_{eff} \quad (5)$$

where (6)

$$g_{eff} = \sqrt{(A_{el}^2 + A_{et}^2 + A_{ev}^2)}$$

$\rho_l$	: Density of liquid
$h_i$	: internal pressure head at CG of element measured from the top of tank to the load point
$A_{el}, A_{et}, A_{ev}$	: Accelerations in longitudinal, transverse and vertical direction respectively are to be calculated using Equation 1.

## 5.5.3 Grain/Ore/Containers

5.5.3.1 Bulk cargo is to be provided in form of mass elements or bulk cargo pressure. The procedure can be followed as given in 5.4.4.3.2 and 5.4.4.3.3:

5.5.3.2 *Mass Element*: The procedure to be followed is indicated in 5.4.3.3. It should be noted that while simulating the cargo as constrained mass element, ship motions (in term of accelerations) are to be provided appropriately at CG of ship to simulate the dynamic loads (quasi-static and inertial).

5.5.3.3 *Bulk Cargo Pressure*: Based on the type of cargo loaded, relevant internal surfaces of cargo hold are to be selected for the cargo pressure application. Assuming, there is no relative motion between cargo hold and filled cargo appropriate bulk cargo pressures are to be applied to the surface of cargo tanks using Equation (7).

5.5.3.4 The following formulation can be utilized for calculation of static and dynamic loads:

$$p_{bn} = \rho_c h_T A_e (\cos^2 \alpha + (1 - \sin \alpha_0) \sin^2 \alpha) \quad 0^\circ \leq \alpha \leq 90^\circ \quad (7)$$

$$p_{bn} = 0 \quad \text{else}$$

$$p_{bt} = \rho_c h_T A_e (\sin \alpha_0 \sin \alpha \cos \alpha) \quad 0^\circ \leq \alpha \leq 90^\circ \quad (8)$$

$$p_{bt} = 0 \quad \text{else}$$

where:

- $\alpha_0$  : Angle of repose for considered bulk cargo
- $\rho_c$  : Density of cargo
- $p_{bn}$  : Normal component of pressure to the cargo tank surface
- $p_{bt}$  : Tangential component of pressure to the cargo tank surface
- $h_T$  : Distance from the top of cargo surface to the load point

- $\vec{n}$  : Unit normal vector of surface in ship's co-ordinate system, towards inside of cargo tank  
 $= n_x \vec{i} + n_y \vec{j} + n_z \vec{k}$
- $A_e$  : Accelerations ( $A_{el}, A_{et}, A_{ev}$ ) at CG of ship to be evaluated using the Equation (1) and can shown in vector form  
 $= A_{el} \vec{i} + A_{et} \vec{j} + A_{ev} \vec{k}$
- $\alpha$  : Angle between the surface unit normal vector  $\vec{n}$  and the acceleration vector  $\vec{A}_e$  can be evaluate as follows (see Figure 5.5.3)  
 $= \cos^{-1} \left( \frac{\vec{A}_e \cdot \vec{n}}{|\vec{A}_e| |\vec{n}|} \right)$

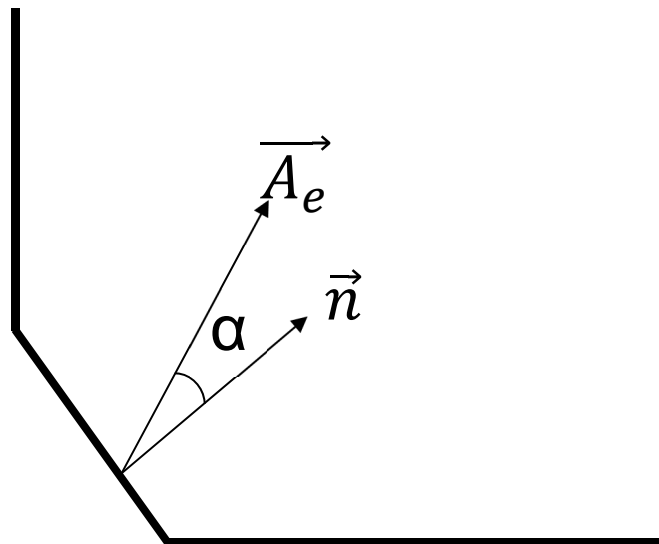

Figure 5.5.3: Illustration of normal vector and acceleration vector at selected surface of tank

5.4.4.3.5 *Containers*: Containers masses are to be simulated as discussed in 5.4.3.4 or in terms of forces. In case of mass elements, all relevant accelerations are to be simulated as discussed in 5.5.1. If mass is simulated as nodal forces than appropriate dynamic forces are to be estimated using accelerations calculated from Equation (1).

5.4.4.3.6 *Lightship weight and Equipment*: Appropriate dynamic load effects are to be considered for the lightship structure and equipment as discussed in 5.5.1.

## 5.6 Pressure Mapping

5.6.1 The fluid pressure has to be mapped onto FE model of ship. An appropriate component is to be created in FE model for application of fluid pressure as shown in Figure 5.6.1 (b). The fluid pressures are to be applied on selected outer hull component of FE model using suitable technique of pressure mapping.

5.6.2 The mapping of panel pressures are performed using the three dimensional linear interpolation scheme. Due to difference in the size of mesh (see Figure 5.6.1(a) and Figure 5.6.1(b)), mapping of pressure induces inherent error which may result in unbalanced forces in FE model. Inertia relief method can be employed to balance the FE model. Inertia relief is a technique in which applied forces and moments are balanced by counter forces induced by accelerating the body. The application of acceleration is performed such a way that it precisely cancels or balances the additional forces. However it should be carefully considered that application of inertia relief can alter the response profile of structure. Application of inertia relief method in ship structures should be done when the unbalanced forces are within engineering limits. Unbalanced forces can be estimated as fraction of total weight of ship. Inertia relief method can be utilized only while performing static analysis. To use this method element mass and/or density must be defined in the FE model.

5.6.3 Figure 5.6.3 (a) and Figure 5.6.3 (b) shows the pressure distribution on the FE model evaluated using the frequency domain for illustration purpose. In case of frequency domain method, the real and imaginary components of pressure are to be applied separately.

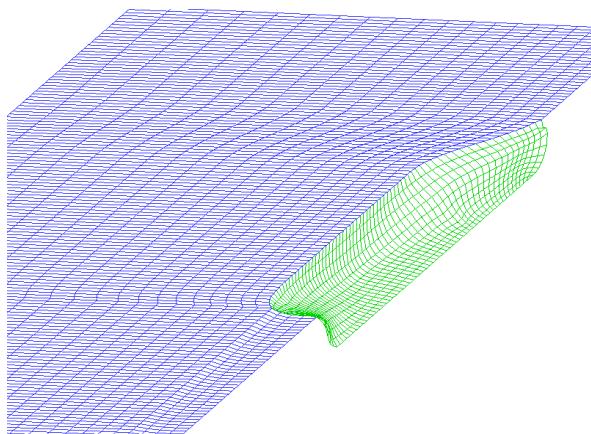

Figure 5.6.1(a): Panel distribution on ship (half breadth) geometry and wave domain

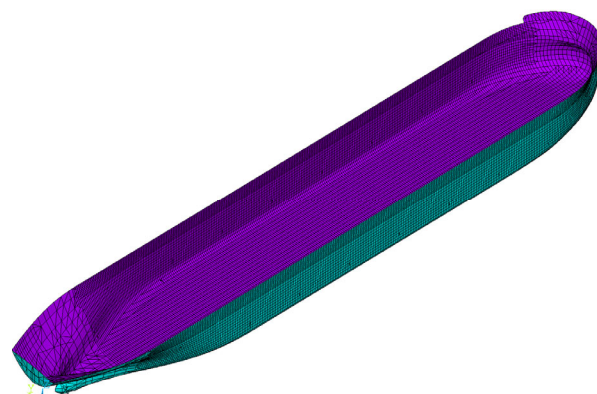

Figure 5.6.1(b): Outer hull component

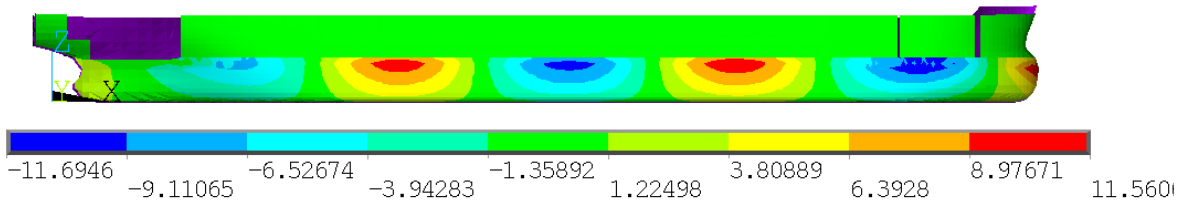

Figure 5.6.3(a): Distribution of real component of complex pressure in frequency domain (Heavy ballast condition, freq. = 0.80)

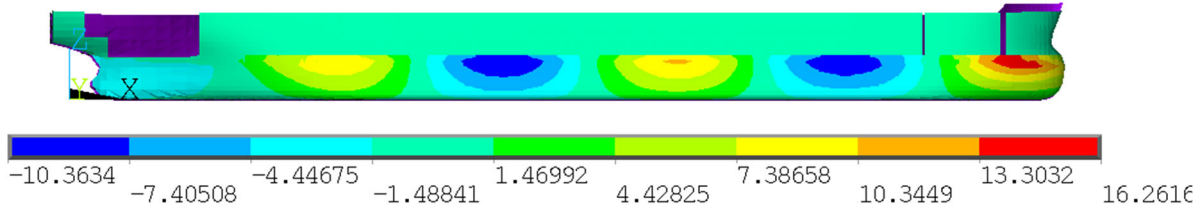

Figure 5.6.3(b): Distribution of imaginary component of complex pressure in frequency domain (Heavy ballast condition, freq. = 0.80)

## 5.7 Boundary Conditions

5.7.1 To simulate the buoyant condition of ship in static structural analysis of ship, some artificial support may be required to be added in FE model. These support reactions are to be minimum in order to capture the actual response of structure. The following boundary conditions can be provided as detailed in Table 5.7.1 and Figure 5.7.1

Table 5.7.1: Boundary conditions for global model		
	Location	Direction
Engine Room Front Bulkhead	SB & PS	Z
	CL	Y
Collision Bulkhead	CL	X, Y, Z

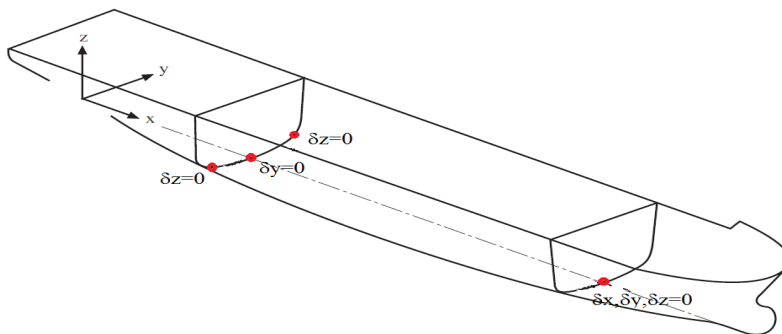

Figure 5.7.1: Boundary conditions

## **5.8 Structural Modelling**

### **5.8.1 General**

5.8.1.1 A three dimensional (3D) global FE model representing the entire hull needs to be created to simulate the structural response using direct hydrodynamic loads. The FE model's geometry, configuration and stiffness are to be closely approximated as the actual structure and to be represented by the suitable elements.

5.8.1.2 A local structure may be required to assess the refined stress distribution in particular area. Local structure is to be provided with the all relevant geometric details with appropriate mesh density. A separate analysis of local structure can be performed using sub-modelling technique. Care should be taken to apply the extracted displacements as the boundary conditions and appropriate loads on local sub-model.

## **5.9 Structural Analysis**

### **5.9.1 General**

5.9.1.1 Static structural analyses are to be performed to get the stress transfer function at considered structural location and for given number of load cases corresponding to each loading condition.

### **5.9.2 Load Cases**

5.9.2.1 Load case is corresponding to a combination of loading condition of vessel, wave heading angle, wave frequency and real and imaginary component of RAOs. In case of spectral fatigue analysis, the number of load cases are typically high e.g. for one loading condition, 12 headings, 25 frequencies and two parts of frequency (real and imaginary) and for a given speed; the number of load cases will be 600 ( $1 \times 12 \times 25 \times 2 \times 1$ ). Apart from these hydrodynamic cases, hydrostatics load cases also need to be considered in the analysis.

### **5.9.3 Equilibrium check**

5.9.3.1 Equilibrium check for each load case is to be carried out mandatorily. The applied hydrodynamic panel pressure is to be in equilibrium with applied loads on the full length structural model of ship. To estimate the imbalance forces all the forces and moments are to be summed up in global direction. In case of unbalanced forces, a suitable method to balance the FE model is to be employed before performing the structural analysis.

### **5.9.4 Analysis Verification**

5.9.4.1 Before proceeding with the structural response evaluation, following needs to be verified with the values given in loading manual or stability booklet:

- Total weight and CG of each tank/hold/ship in each loading condition
- Shear force distribution along the length of ship
- Moment distribution along the length of ship

### **5.9.5 Stress Extraction**

5.9.5.1 The appropriate stress should be extracted from the FE model to get the hot-spot stress for fatigue analysis. The procedure to get the hot-spot stress are to be followed as indicated in **Appendix 3**.

## Section 6

### Spectral Analysis

#### 6.1 General

6.1.1 The structural response termed as stress range transfer function or Stress *RAO* are to be obtained from the Global *FE* analysis as described in Section 5. The stress *RAOs* are to be obtained for different wave heading, vessel speed and loading condition and can be represented as

$$H_{\sigma}(\omega | \theta) = RAO_{\sigma}$$

6.1.2 A suitable scatter diagram is to be referred based on the area of operation or trade route or service type as discussed in Section 3.

6.1.3 A spectral model is to be selected to represent the short term sea states of the scatter diagram as discussed in Section 3.

6.1.4 Short-term Stress response is to be obtained for the sea states, directions and speed by linear superposition principle of the spectral method.

6.1.5 Short-term statistical properties of interest for *SFA* can be derived from the stress response spectrum considering appropriate distribution law.

#### 6.2 Response Spectrum

6.2.1 The spectral density of the response can be obtained as:

$$S_{\sigma}(\omega | H_s, T_z, \theta) = |H_{\sigma}(\omega | \theta)|^2 \cdot S_{\xi}(\omega | H_s, T_z)$$

#### 6.3 Spectral Moments

6.3.1 Cosine-squared spreading is assumed from +90 to -90 Degrees on either side of the selected dominant wave heading, Spectral moments can be computed using following expression:

$$m_n = \int_{\theta=-90}^{\theta=+90} \int_0^{\infty} \left( \omega - \frac{V\omega^2}{g} \cos \theta' \right)^n S_{\sigma}(\omega | H_s, T_z, \theta) \left( \frac{2}{\pi} \cdot \cos^2 \theta' \right) d\omega d\theta$$

Where,  $\theta'$  is the spreading angle between a wave component and the dominant wave direction.

6.3.2 Using the spectral moments, the Rayleigh probability density function (pdf) describing the short term stress-range distribution, the zero up-crossing frequency of the stress response and the bandwidth parameter used in calculating Wirsching's "rainflow correction" are calculated as follows:

Rayleigh probability density function:

$$p(\sigma_R) = \frac{\sigma_R}{4\sigma_0^2} \exp\left(-\frac{\sigma_R^2}{8\sigma_0^2}\right)$$

Zero-up crossing frequency, in Hz:

$$n_\sigma = \frac{1}{2\pi} \sqrt{\frac{m_2}{m_0}}$$

Bandwidth parameter:

$$\varepsilon = \sqrt{1 - \frac{m_2^2}{m_0 m_4}}$$

Where,

- $\sigma_0 = \sqrt{m_0}$  = root mean square of the stress range.
- $p(\sigma_R)$  = stress range probability distribution function
- $\sigma_0$  = standard deviation of the stress process
- $\sigma_R$  = stress range
- $m_0, m_1, m_2, m_3, m_4$  = are the spectral moments.

## 6.4 Rain-flow Correction

6.4.1 Loading process in ocean environment follows wide band spectrum. A suitable wide band correction factor is required to include in the analysis to avoid conservatism due to narrow band assumption.

6.4.2 Wrisching and Light's empirical formulation based wide band correction factor is represented by following equation

$$\lambda(m, \varepsilon) = a(m) + [1 - a(m)][1 - \varepsilon]^{b(m)}$$

Where,

$\varepsilon$  = Spectral bandwidth

$$a(m) = 0.926 - 0.033m, \quad b(m) = 1.587m - 2.323$$



## Section 7

### Fatigue Damage Assessment

#### 7.1 General

7.1.1 The loads are represented by the stress range distributions while the fatigue capacity against cyclic loads is represented by *S-N* curves.

7.1.2 The stress spectra are combined with *S-N* curves, and the short-term fatigue damage at concerned location is calculated using Palmgren-Miner's linear cumulative damage rule.

7.1.3 The long-term fatigue damage is obtained by linear summation of short term damages, weighted by the occurrence probability of sea state and numbers of stress response cycles for the same sea state.

7.1.4 Spectral fatigue life is not to be less than the design fatigue life. This is an obligatory requirement for assigning the **SFA** notation.

#### 7.2 Fatigue Stress Range

7.2.1 The fatigue stress range for each load case is to be obtained and corrected for mean stress effect, thickness effect and material factor. IRS Rules may be referred to calculate these effects and factors.

$$\sigma_R = f_{mean} f_{thickness} f_{material} \cdot \Delta\sigma$$

Where,

$\sigma_R$	= Calculated fatigue stress range for single load case and loading condition
$\Delta\sigma$	= Hot spot stress range for single load case and loading condition
$f_{mean}$	= Mean stress effect
$f_{thickness}$	= Thickness effect
$f_{material}$	= Material factor

#### 7.3 S-N Curves

7.3.1 Selection of *S-N* curve is influenced by various factors like corrosion protection, plate thickness, mean stress effect, weld improvement techniques etc. Therefore, adjustment for the mentioned effects are to be taken into account in agreement with IRS.

7.3.2 The selection of *S-N* curve class, based on the welded joint geometry is to be performed as indicated in **Appendix – 2**.

#### 7.4 Fatigue Strength

7.4.1 Fatigue strength is expressed by the cumulative damage ratio for the expected ship life. Palmgren-Miner Rule is used to determine accumulated short term fatigue for the selected stress approach. For a loading condition, the fatigue damage is given by:

$$D = \sum_{i=1}^{n_t} \frac{n_i}{N_i}$$

Where,

- $n_i$  = Number of cycles of constant amplitude stress range,
- $N_i$  average number of loading cycles to failure under constant amplitude loading at that stress range
- $n_t$  = total number of considered stress ranges interval blocks.

The short term damage sustained in the  $i$ -th sea-state, assuming single slope S-N curve of the form  $N = K_2 S^{-m}$ , is given by:

$$D_i = \left(\frac{T_0}{K_2}\right) \int_0^{\infty} S^m n_{\sigma} p(\sigma_R) d\sigma_R$$

Where,  $T$  = design fatigue life, in seconds

## 7.5 Close Form Damage Expressions

7.5.1 Fatigue damage based on single slope S-N curve, representing Rayleigh distribution within each sea state, all sea states, all wave headings and single loading condition is given by

$$D = v_0 T_0 \cdot \frac{\Gamma\left(1 + \frac{m}{2}\right)}{K_2} \sum_{\substack{\text{All Seastates} \\ \text{All headings}}} \sum_{\substack{i=1 \\ j=1}} v_{ij} \left(2\sqrt{2m_{0ij}}\right)^m$$

Where,

- $v_0$  = long-term average zero-up-crossing-frequency (Hz)
- $T_0$  = Design life in seconds.

7.5.2 Total fatigue damage for double slope S-N curve, representing Rayleigh distribution within each sea state, all wave headings and single loading conditions is given by the following equation:

$$D = v_0 T_0 \cdot \sum_{\substack{\text{All Seastates} \\ \text{All headings}}} \sum_{\substack{i=1 \\ j=1}} v_{ij} \left( \frac{(2\sqrt{2m_{0ij}})^{m_1}}{K_2} \Gamma\left(1 + \frac{m_1}{2}; \left(\frac{S_0}{2\sqrt{2m_{0ij}}}\right)^2\right) + \frac{(2\sqrt{2m_{0ij}})^{m_2}}{K_3} \gamma\left(1 + \frac{m_2}{2}; \left(\frac{S_0}{2\sqrt{2m_{0ij}}}\right)^2\right) \right)$$

Where,

- $S_0$  = Stress range for which change of slope of S-N curve occur
- $K_2, m_1$  = S-N fatigue parameters for  $N < 10^7$  cycles
- $K_3, m_2$  = S-N fatigue parameters for  $N > 10^7$  cycles
- $\gamma$  = Incomplete Gamma function
- $\Gamma$  = Complementary Incomplete Gamma function

## 7.6 Combined Fatigue Damage

7.6.1 Total fatigue damage is taken as a sum of damage occurring in a particular loading condition times the fraction of time spent in each of the loading conditions. For multiple loading conditions, fatigue damage can be specified as  $D_1, D_2 \dots D_n$ . The combined fatigue damage is given by:

$$D = \sum_{l=1}^n c_l D_l$$

Where,

- $l$  = Loading condition.
- $n$  = Total number of the loading conditions.
- $C$  = Fraction of time spent in each of the loading condition.

7.6.2 Fatigue damage assessment can be represented as either in term of damage ratio (D) or design fatigue life ( $L_0$ ). In this guideline the design fatigue life has been selected for the assessment of fatigue strength.

$$L_0 = \alpha_s \frac{T_s}{D}$$

Where,

- $T_s$  = Ship service life (years)
- $\alpha_s$  = 0.85, factor accounted for the exclusion of port and harbor operations.

## 7.7 Acceptance Criteria

7.7.1 The calculated fatigue life is to be greater than or equal to the design fatigue life, as an obligatory requirement for assigning **SFA** notation.

For CSR vessels, calculated fatigue life ( $L_0$ ) needs to be greater than or equal to 25 years.

In general,

$$L_0 \geq T_s$$

**Appendix – 1 ‘Scatter Diagram’**

**Table A.1.1 – Probability of sea-states in the North Atlantic**

$H_s/T_z$	3.5	4.5	5.5	6.5	7.5	8.5	9.5	10.5	11.5	12.5	13.5	14.5	15.5	16.5	17.5	18.5	Sum
0.5	1.3	133.7	865.6	1186.0	634.2	186.3	36.9	5.6	0.7	0.1	0.0	0.0	0.0	0.0	0.0	0.0	3050.4
1.5	0.0	29.3	986.0	4976.0	7738.0	5569.7	2375.7	703.5	160.7	30.5	5.1	0.8	0.1	0.0	0.0	0.0	22575.4
2.5	0.0	2.2	197.5	2158.8	6230.0	7449.5	4860.4	2066.0	644.5	160.2	33.7	6.3	1.1	0.2	0.0	0.0	23810.4
3.5	0.0	0.2	34.9	695.5	3226.5	5675.0	5099.1	2838.0	1114.1	337.7	84.3	18.2	3.5	0.6	0.1	0.0	19127.7
4.5	0.0	0.0	6.0	196.1	1354.3	3288.5	3857.5	2685.5	1275.2	455.1	130.9	31.9	6.9	1.3	0.2	0.0	13289.4
5.5	0.0	0.0	1.0	51.0	498.4	1602.9	2372.7	2008.3	1126.0	463.6	150.9	41.0	9.7	2.1	0.4	0.1	8328.1
6.5	0.0	0.0	0.2	12.6	167.0	690.3	1257.9	1268.6	825.9	386.8	140.8	42.2	10.9	2.5	0.5	0.1	4806.3
7.5	0.0	0.0	0.0	3.0	52.1	270.1	594.4	703.2	524.9	276.7	111.7	36.7	10.2	2.5	0.6	0.1	2586.2
8.5	0.0	0.0	0.0	0.7	15.4	97.9	255.9	350.6	296.9	174.6	77.6	27.7	8.4	2.2	0.5	0.1	1308.5
9.5	0.0	0.0	0.0	0.2	4.3	33.2	101.9	159.9	152.2	99.2	48.3	18.7	6.1	1.7	0.4	0.1	626.2
10.5	0.0	0.0	0.0	0.0	1.2	10.7	37.9	67.5	71.7	51.5	27.3	11.4	4.0	1.2	0.3	0.1	284.8
11.5	0.0	0.0	0.0	0.0	0.3	3.3	13.3	26.6	31.4	24.7	14.2	6.4	2.4	0.7	0.2	0.1	123.6
12.5	0.0	0.0	0.0	0.0	0.1	1.0	4.4	9.9	12.8	11.0	6.8	3.3	1.3	0.4	0.1	0.0	51.1
13.5	0.0	0.0	0.0	0.0	0.0	0.3	1.4	3.5	5.0	4.6	3.1	1.6	0.7	0.2	0.1	0.0	20.5
14.5	0.0	0.0	0.0	0.0	0.0	0.1	0.4	1.2	1.8	1.8	1.3	0.7	0.3	0.1	0.0	0.0	7.7
15.5	0.0	0.0	0.0	0.0	0.0	0.0	0.1	0.4	0.6	0.7	0.5	0.3	0.1	0.1	0.0	0.0	2.8
16.5	0.0	0.0	0.0	0.0	0.0	0.0	0.0	0.1	0.2	0.2	0.2	0.1	0.1	0.0	0.0	0.0	0.9
	1.3	165.4	2091.2	9279.9	19921.8	24878.8	20869.9	12898.4	6244.6	2479.0	836.7	247.3	65.8	15.8	3.4	0.7	10000

## Appendix – 2 ‘Design S-N Curves’

### A.2.1 General

A.2.1.1 The capacity of welded steel joints with respect to the fatigue strength is characterized by *S-N* curves which give the relationship between the stress ranges applied to a given detail and the number of constant amplitude load cycles to failure.

A.2.1.2 All experimental data of *S-N* curves are defined by their mean fatigue life and their standard deviation.

### A.2.3 Design S-N Curves

A.2.3.1 Unless supported by direct measurements, the U.K. HSE (previously DEn) basic *S-N* Curves are to be used for determining the fatigue life. If other data is used then background and other supporting documents are to be submitted for review to IRS.

A.2.3.2 Defined *S-N* curves are applicable to steels with minimum yield strength less than 400 N/mm<sup>2</sup>. For steels with higher yield strength, data obtained from an approved test programme are to be used.

### A.2.4 U.K. HSE S-N Curves

A.2.4.1 The HSE *S-N* Curves for non-tubular joints consist of eight curves, as shown in Table A.2.1 identified by B, C, D, E, F, F2, G and W categories. These curves give the relationship between the nominal stress range and the number of constant amplitude load cycles to failure. Each curve represents a class of weld details depending upon:

- The geometrical arrangement of the detail
- The direction of the fluctuating stress relative to the detail
- The method of fabrication and inspection of the detail.

A.2.4.2 The fatigue life (in cycles) corresponding to a given stress range is to be evaluated as shown below:

$$S^m N = K_2$$

where:

<i>S</i>	: Evaluated Stress range at given structural detail where fatigue life is to be evaluated
<i>N</i>	: Number of cycles to failure
<i>K<sub>2</sub></i>	: Constant depending upon the material and weld type, type of loading, geometrical configuration and environmental conditions
<i>m</i>	: Constant depending upon the material and weld type, type of loading, geometrical configuration and environmental conditions

A.2.4.3 The S-N curves specified in the rules correspond to non corrosive conditions and are specified for mean minus two standard deviations. This is demonstrated as shown below:

$$\text{Log}(N) = \text{Log}(K_2) - m\text{Log}(S)$$

where:

$$\text{Log}(K_2) = \text{Log}(K_1) - 2\delta$$

- $N$  : as defined in A.2.4.2
- $K_1$  : Constant relating to the mean SN curve as shown in *Table A.2.1*
- $\delta$  : Standard deviation of  $\text{log}(N)$
- $m$  : Inverse slope of the SN curve as defined in A.2.4.2
- $S_q$  : Stress range corresponding to  $10^7$  cycles of the SN curve as shown in *Table A.2.1*

A.2.4.4 For plate thicknesses greater than 22mm, the number of cycles  $N$  is to be evaluated as shown below:

$$\text{Log}(N) = \text{Log}(K_2) - m\text{Log}\left[\frac{S}{\left(22/t_{net50}\right)^{0.25}}\right]$$

where:

- $\text{Log}(N)$  : as defined in A.2.4.3
- $\text{Log} K_2$  : as defined in A.2.4.3
- $m$  : as defined in A.2.4.2
- $S$  : Stress range at structural detail corresponding to the loading condition
- $t_{net50}$  : Net thickness considering 50% deduction of corrosion additions.

A.2.4.5 The effects of mean stress are to be accounted for during the life cycles evaluation. The consideration of benefits of weld improvements on the fatigue life is to be agreed with IRS.

A.2.4.6 The considerations in the present section are applicable for welded joints in air or exposed to sea water based upon the consideration that suitable corrosion protection in form of coating is provided. For unprotected joints exposed to sea water, the fatigue life cycles obtained from A.2.4.3 or A.2.4.4 are to be reduced by a factor of 2.

A.2.4.7 Selection of the appropriate SN curve for a structural detail can be made considering the guidelines in *Table A.2.2* considering that the nominal stress range ( $S$ ) is evaluated as shown in A.2.4.2. For hotspot stress ranges evaluated using *FEM*, the D category SN curve may be utilized.

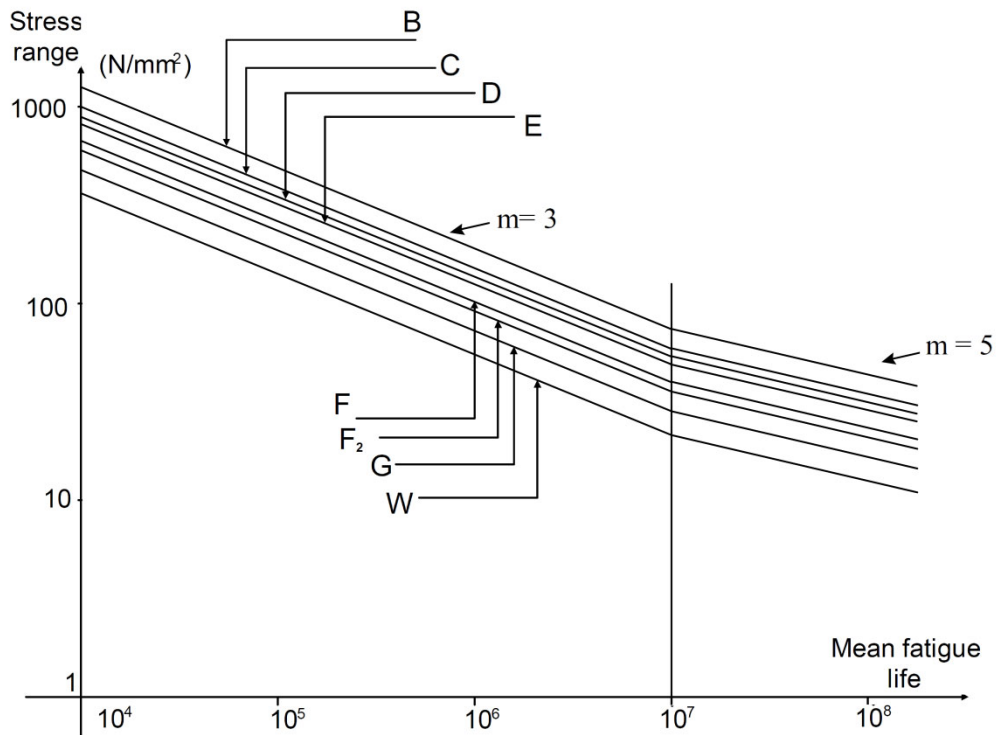

Figure A.2.1: Basic S-N curves (in-Air)<sup>1</sup>

Table A.2.1: SN Curves

SN curve Category	$K_1$			$m$	$\Delta$		$K_2$	$S_q$ (N/mm <sup>2</sup> )
		$\log_{10}$	$\log_e$		$\log_{10}$	$\log_e$		
B	2.343E15	15.3697	35.3900	4.0	0.1821	0.4194	1.01E15	100.2
C	1.082E14	14.0342	32.3153	3.5	0.2041	0.4700	4.23E13	78.2
D	3.988E12	12.6007	29.0144	3.0	0.2095	0.4824	1.52E12	53.4
E	3.289E12	12.5169	29.8216	3.0	0.2509	0.5777	1.04E12	47.0
F	1.726E12	12.2370	28.1770	3.0	0.2183	0.5027	0.63E12	39.8
F <sub>2</sub>	1.231E12	12.0900	27.8737	3.0	0.2279	0.5248	0.43E12	35.0
G	0.566E12	11.7525	27.0614	3.0	0.1793	0.4129	0.25E12	29.2
W	0.368E12	11.5662	26.6324	3.0	0.1846	0.4251	0.16E12	25.2

**Table A.2.2: Welded Joint Classification for SN curve**

SN curve category for Joint Classification	Description <sup>[1]</sup>
Category B	1) Parent metal in the as-rolled condition with no flame-cut edges or with flame-cut edges ground or machined 2) Full penetration butt welds with the weld cap ground flush with the surface and with the weld proved to be free from defects by NDT.
Category C	1) Parent material in the as-rolled condition with automatic flame-cut edges and ensured to be free from cracks. 2) Butt or fillet welds made by an automatic submerged or open arc process and with no stop-start positions within their length. 3) With the weld cap ground flush with the surface and with the weld proved to be free from significant defects by NDT.
Category D	1) As C(2) but with stop-start positions within the length 2) with the welds made either manually or by an automatic process other than submerged arc and in flat position
Category E	1) Intermittent fillet welds
Category F	1) Welds made on a permanent backing strip between plates of equal width and thickness or tapered with a maximum slope of 1/4. 2) Parent material (of the stressed member) or ends of butt or fillet welded attachments (parallel to the direction of applied stresses) on stressed members : - attachment length $l \leq 150$ mm - edge distance $d \geq 10$ mm 3) Parent metal of cruciform or T Joints made with full penetration welds and with any undercut at the corners of the member ground out 4) Parent metal at the toe of weld connection of web stiffeners to girder flanges: edge distance $d \geq 10$ mm As E(1) but adjacent to cut-outs.
Category F2	1) Parent material (of the stressed member) or ends of butt or fillet welded attachments (parallel to the direction of applied stresses) on stressed members : - attachment length $l > 150$ mm - edge distance $d \geq 10$ mm 2) As F(3) with partial penetration or fillet welds with any undercut at the corners of the member ground out. 3) Parent metal of load-carrying fillet welds transverse to the direction of stresses (member X): edge distance $d \geq 10$ mm
Category G	1) Parent material (of the stressed member) at toes or ends of butt or fillet welded attachments on or within 10 mm of edges or corners. 2) Parent metal of load-carrying fillet welds transverse to the direction of stresses (member X): edge distance $d < 10$ mm 3) Parent metal of load-carrying fillet welds parallel to the direction of stresses, with the weld end on plate edge (member Y). 4) Parent metal at the toe of weld connection of web stiffeners to girder flanges: edge distance $d < 10$ mm
<sup>1</sup> For additional guidance also refer Offshore Installations – Guidance on Design, Construction and Certification: Health & Safety Executive, UK.	



**Appendix – 3 ‘Hot-spot Stress Extraction’**

**A.3 Stress Extraction for Fatigue**

A.3.1 The hot-spot stress is normally used for fatigue assessment of welded joints. The hot spot stress includes all stress-rising effects induced by the structural detail (geometrical changes). The local stresses are to be obtained at reference point and extrapolate to weld toe under consideration.

A.3.2 Meshing size and the limitation to weld configurations are to be referred from the IIW recommendation.

A.3.3 IIW recommendation for fatigue design of welded joints (IIW-1823-07) is utilized for extraction of hot spot stress. Two types of hot-spot stresses are defined based on the location on the plate and its orientation in respect to weld toe listed in the Table A.3.3 and shown in the Figure A.3.3. UK HSE (UK Department of Energy (DEn), 1990) derive the S-N curves based on the stress range normal to weld.

A.3.4 In case of biaxial stress state at the plate surface, the principal stress which acts approximately in line with the perpendicular to weld toe (within  $\pm 60^\circ$  see Figure A.3.4) are to be used. The other principal stress may need to be analyzed, if necessary, using the fatigue class in the nominal stress approach for welds parallel to the stress (IIW-1823-07).

A.3.5 Extraction of hot-spot stress depends on the size of fine mesh of structural model. The element size of fine mesh is to be taken as per the IIW-1823-07.

Table A.3.3: Type of hot-spot stress	
Type	Description
a	Hot-spot at weld toe on plate surface
b	Hot-spot at weld toe at plate edge

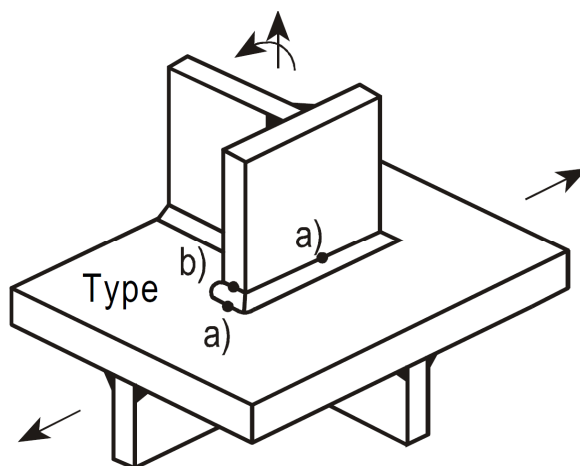

**Figure A.3.3: Type of hot-spot stress**

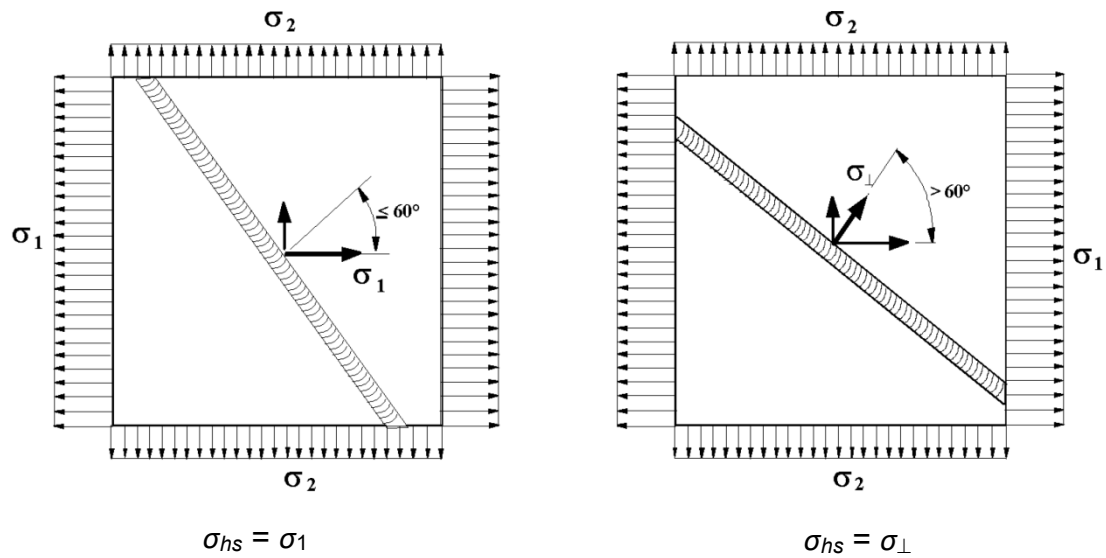

Figure A.3.4: Biaxial stress at weld toe

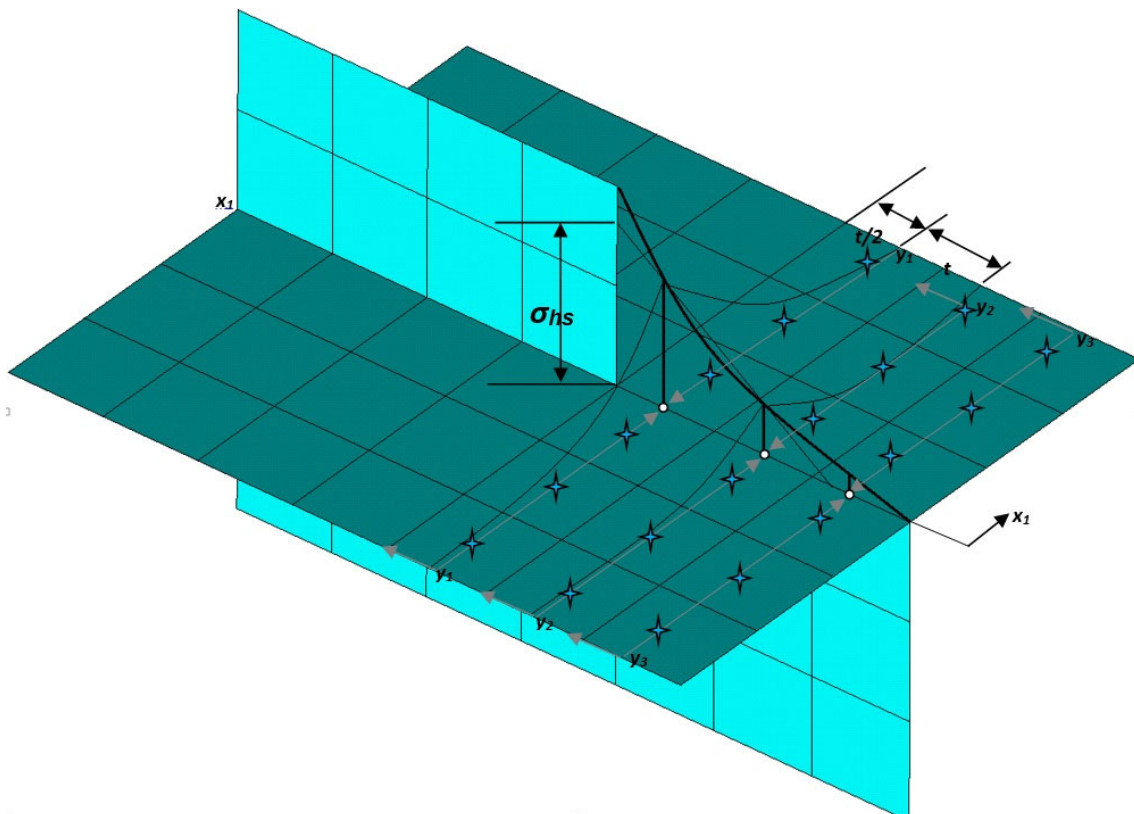

Figure A.3.6: Determination of hot-spot stress using reference points

A.3.6 Stress extrapolation for a fine mesh model ( $t \times t$ ): Reference points are selected as per the IIW recommendation IIW-1823-07 (IIW, 2008). The typical stress extrapolation reference point and path for determining the hot-spot stress for a plate component is indicated in Figure A.3.6. Stresses at the centre of element are to be extrapolated (linear or 2nd order) to  $x_1$ - $x_1$  to get the stresses at reference points located at  $t/2$ ,  $3t/2$  and  $5t/2$ . Extrapolated stress at reference points are to be used to get the hot-spot stress ( $\sigma_{hs}$ ) by linear extrapolation at hot-spot point as shown in Figure A.3.6; where  $t$  is thickness of plate element. For other type of mesh sizes refer IIW-1823-07.

## References:

IIW (2008) *Recommendation of fatigue design for welded joints and components - IIW-1823-07*. Paris, France.

UK Department of Energy (DEn) (1990) *Offshore installations: guidance on design and construction*. London.

IRS (2016) *Review Report – Strength assessment of ships and offshore structures by direct application of wave induced loads*. Project No. RIC-16004-RR. Mumbai

Negi, A., Parihar, Y. and Vhanmane, S. (2019) '*Spectral Fatigue Analysis of Ship - Part 1: Using Beam Theory Based Structural Responses*', in International Conference on Ship and Offshore Technology. Kharagpur, india: RINA, pp. 18–25.

Parihar, Y., Negi, A. and Vhanmane, S. (2019) '*Spectral fatigue analysis of a ship - Part 2: using fem based structural responses*', in International Conference on Ship and Offshore Technology. Kharagpur, india: RINA, pp. 136–142.